

HSE 75 Series Stainless Steel Single/Duct Cover

Stainless steel hinged floor access covers for hard finishes

Features

- Covers can be fitted quickly and unobtrusively into all types of hard floor finish: ceramic tiles, marble, terrazzo, resin or parquet.
- Cover sections are tapered for easy removal, and frame sections give good key to bedding mortar. Covers are precision-made to avoid distortion.
- Double seals are available on HSE 75 series.
- Lifting blocks are anchored to the inner frame. Stainless steel securing bolts are stiletto heel proof.
- Quality control to BS EN ISO 9001.

General notes on HSE 75 series floor access covers

Size – All covers are made to measure. This allows the manufacture of any size between the stated maximum and minimum dimensions. Sizes that may be thought 'non-standard' can therefore be obtained without delay and without cost surcharge. The versatile nature of the Howe Green system allows any configuration of ducts and branches to be created.

Weight – The weight of the access cover should be taken into account where ease of handling is an important consideration. In all cases reference should be made to the Manual Handling Operations Regulations 1992, which implement European Directive 90/269/EEC.

SS

S

D

5
Tonnes

HSE 75 Series Stainless Steel Single/Duct Cover

hinged floor access covers for cars and light delivery vehicles

Typical floor finishes

Ceramic tiles, marble, terrazzo, concrete, resin, wood and all hard floors.

Performance

Up to 5 tonne pneumatic tyre wheel load (cars and light delivery vehicles).

Options

Double Seal. Fire rating to BS 476: Part 20: 1987 available; ask for indicative test report. Under side release hatch.

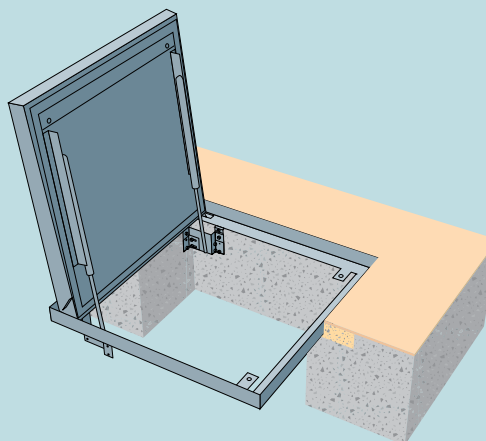

Cross section showing concrete sub-floor

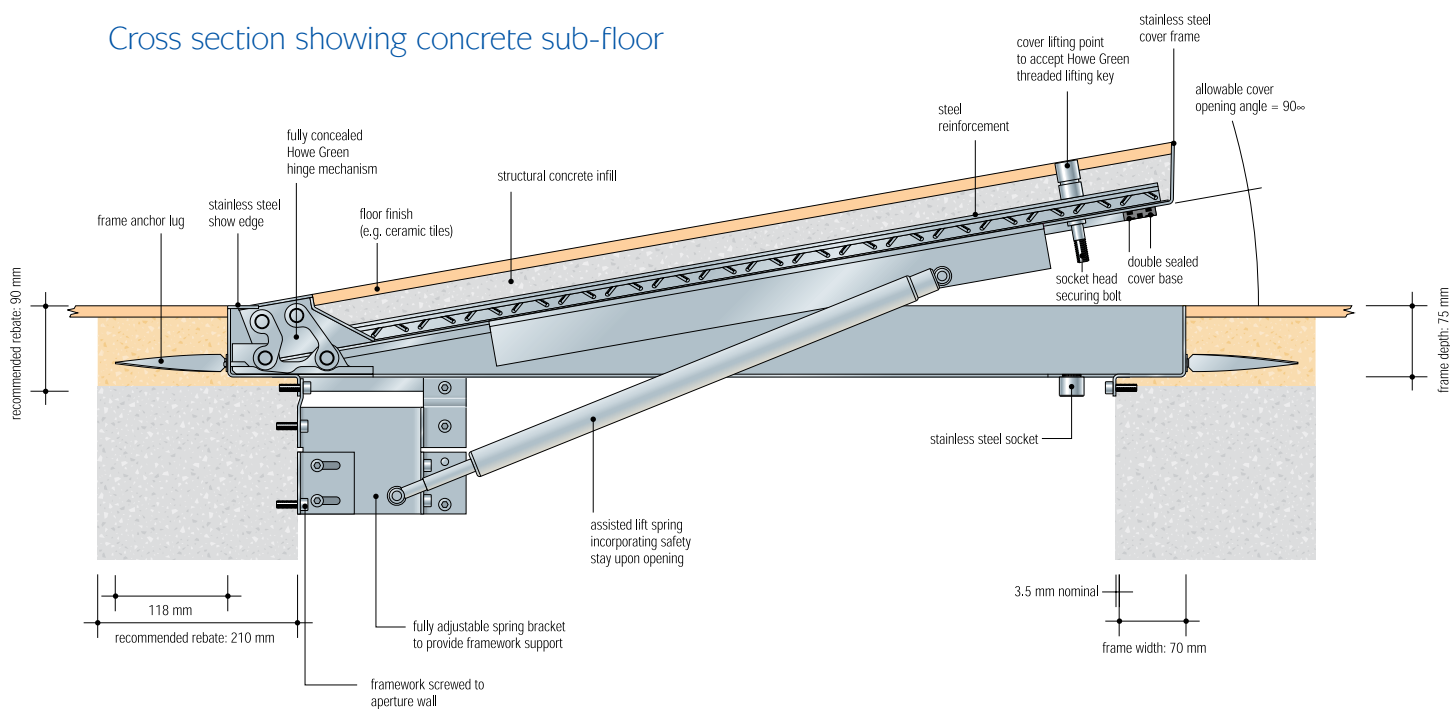

Typical specification clause for HSE 75 series

Recessed floor access hatch shall be Howe Green Ltd HSE 75 series, with fire rating to BS 476: Part 20: 1987*, aluminium/stainless steel show edge*, hatch to be fitted with concealed multi-link hinges, gas springs, stainless steel/steel* base plate, reinforcement and double seal, top and underside release/top release only*. Sizes shall be as shown on contract drawings nos† Covers to be supplied complete with† sets of combined lifting/securing keys. All to be manufactured and supplied by Howe Green Ltd, Marsh Lane, Ware, Hertfordshire, SG12 9QQ, Great Britain, and installed in accordance with the manufacturer's installation details and sitework guide.

* Delete as appropriate. † Insert appropriate numbers & quantities

Size

Overall frame size = clear opening + 147 mm e.g. 600 mm clear opening = 747 mm overall frame width. Subject to correct infill/installation (see separate guide). See also general notes on other side.

Weight

A HSE 75 series access hatch when filled and installed correctly will require a maximum force of 20 kg to open.

Maximum / minimum sizes

